

Graphical Guide to EN81-70

Published in May 2003, the Harmonised European Standard EN81-70 specifies the requirements for accessibility to lifts for persons including persons with disability.

This document summarises the important points of EN81-70 in a concise, graphical format. There are some omissions and there are some combinations which are open to negotiation as well as certain clauses which can be interpreted in different ways. Consequently this document should not be used as a replacement for the specification but more as an introductory guide. Anyone specifying, installing or refurbishing a lift should really make reference to the full specification.

Furthermore, EN81-70 refers to several other European specifications (some of which are published and some of which are still in preliminary draft form) that should be conformed to as a pre-requisite and are not covered in this document. They are EN 81-1 EN 81-2, prEN 81-5, prEN 81-6, prEN 81-7, prEN 81-21, EN 81-28 and EN 13015. Reference should also be made to relevant British Standards documents including BS8300.

EN81-70 Requirements for the landing.

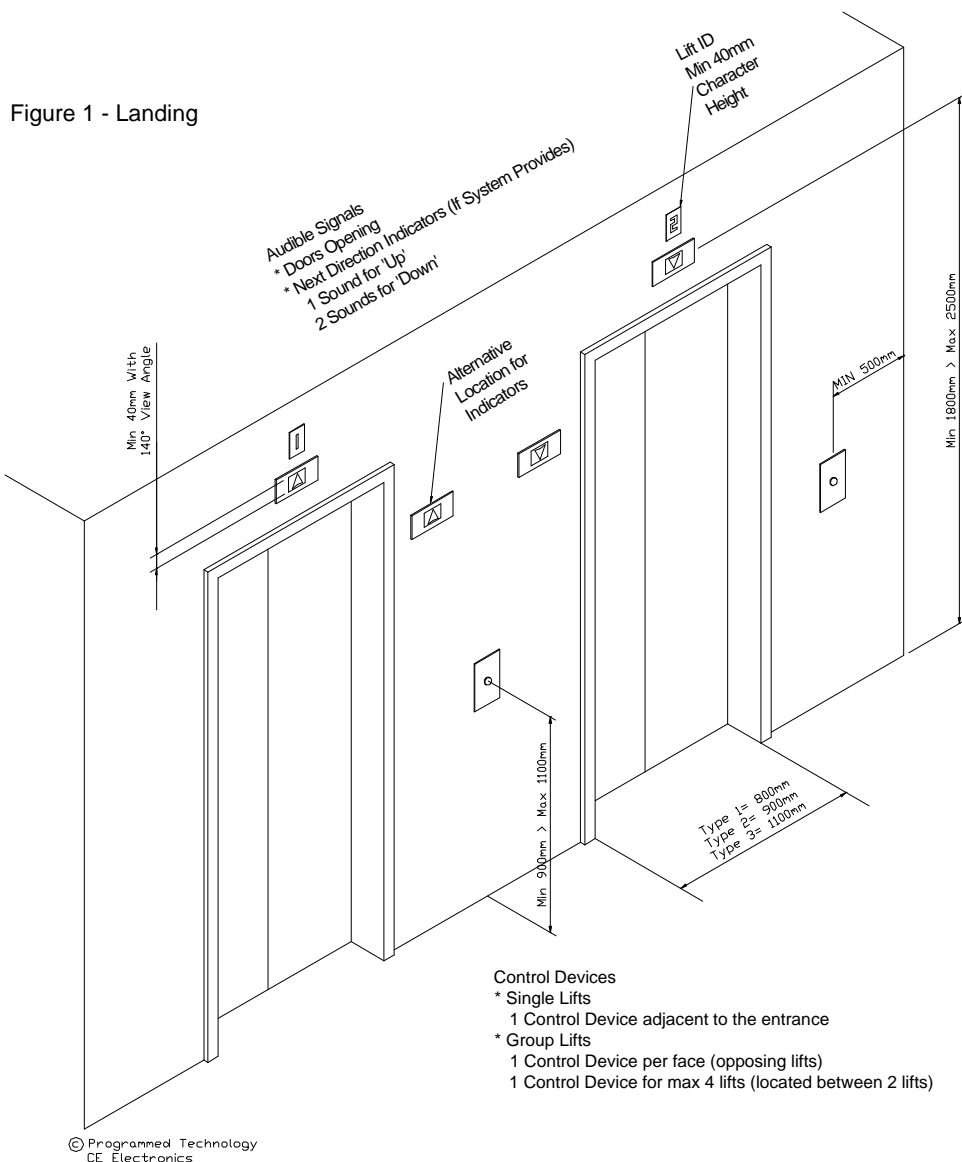

EN81-70 Requirements for the car.

Figure 2 - CAR

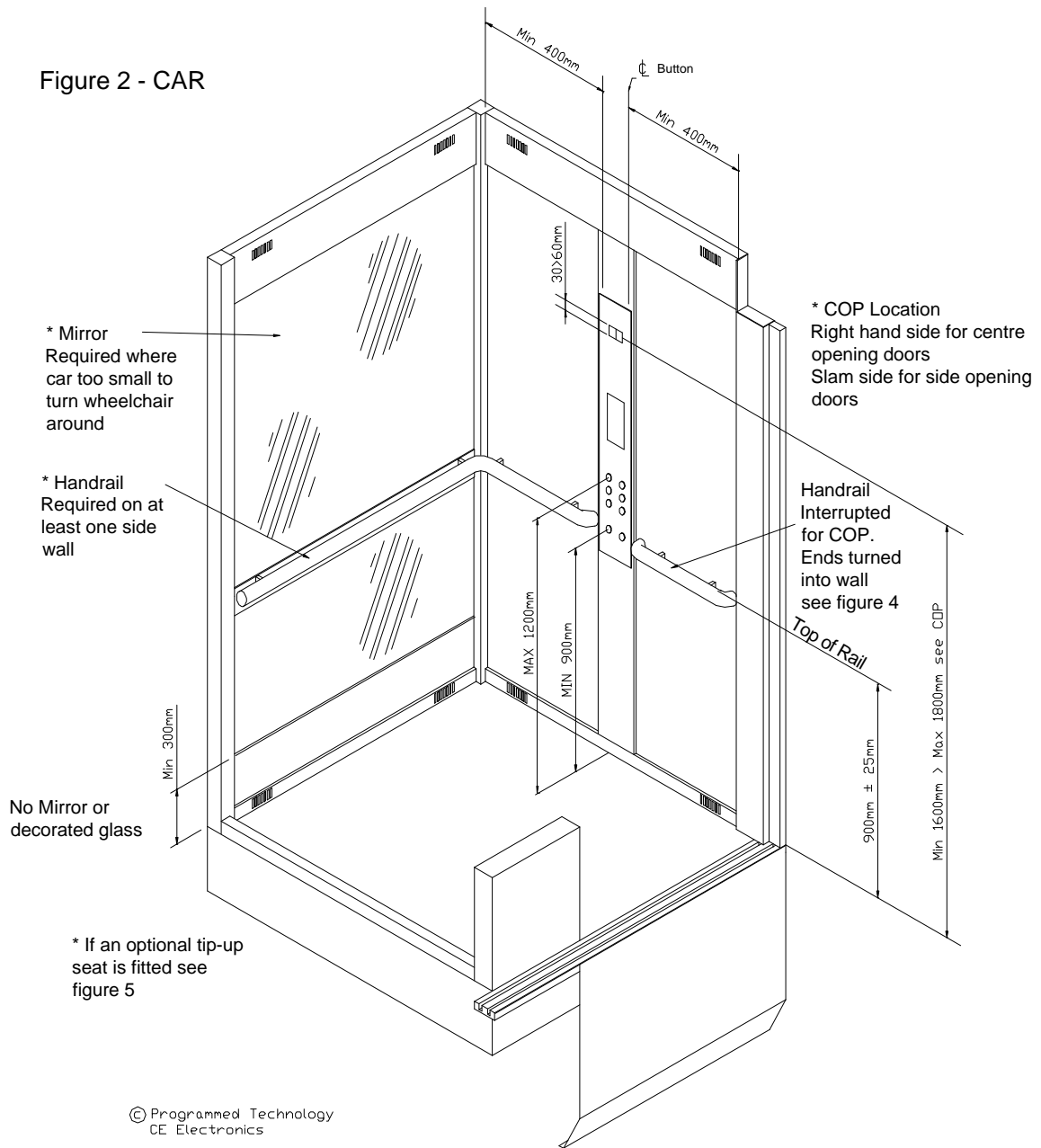

Figure 3 - Car Operator Panel

* Alarm System to EN81-28
(Auto dial unit) see below

* Voice Synthesiser
When the car stops, indicates
car position in at least one
local language

* Car Push Buttons to be
identifiable visually and by
touch from face plate

* Main Exit Floor Button
Protrudes 4-6mm beyond
other buttons - colour green

A = Distance between buttons - min 10mm
B = Distance between button groups - min 2 x A

Alarm & Door Open/Close Buttons

Alarm – Yellow Bell Symbol 

Door Open 

Door Close 

See Figure 6

* Note - the alarm system should provide a yellow
illuminated pictogram indicating alarm given and
a green illuminated pictogram indicating voice link
is active.

Voice link sound level to be min 35dB(A)
max 65dB(A) adjustable

* Emergency messages to be couple with an
induction loop amplifier compatible with
electronics hearing aids.

© Programmed Technology
CE Electronics

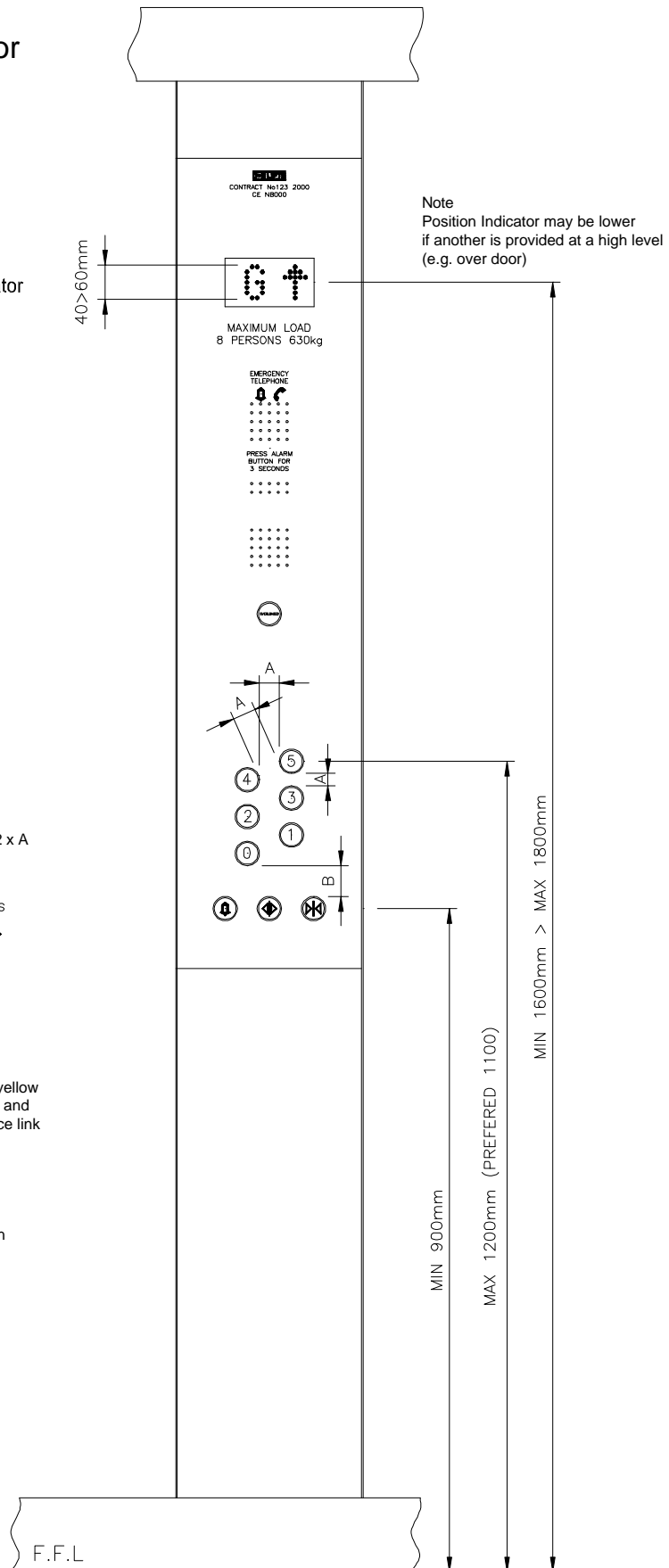
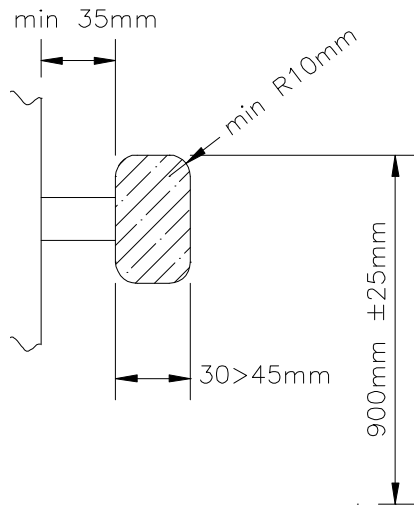
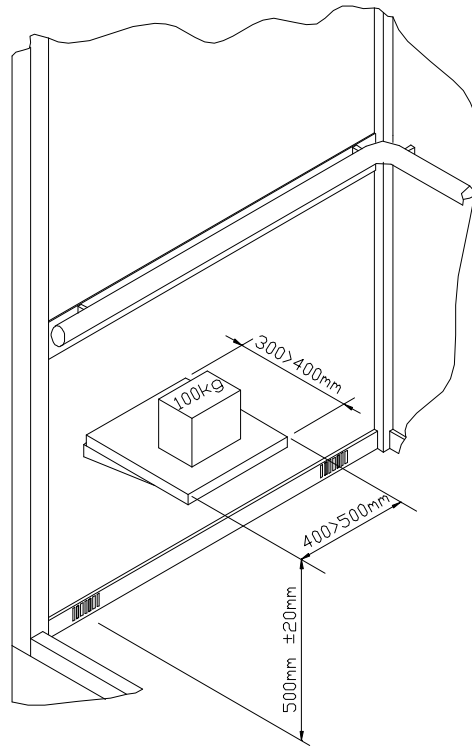

Figure 4 - Handrail



© Programmed Technology
CE Electronics

Figure 5 - Tip Up Seat



© Programmed Technology
CE Electronics

Figure 6 - Control Devices

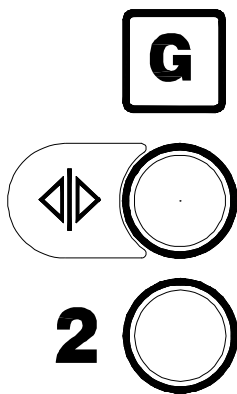

Car Push Buttons to be identifiable visually and by touch from the surrounding face plate

Minimum Area of active part of button 490mm²

Faceplate to colour contrast with surrounds

Operating Force 2.5 to 5.0N

Operation Feedback to the user once button is pushed

Registration Feedback to user to be visible & audible

Adjustable between 35dB(A) and 65dB(A)

Sounding on every push even if registered

Size of Symbol 15 to 40mm

Height of Relief min 0.8mm

Symbol on active part of device or 10-15mm left of it

© Programmed Technology
CE Electronics

These diagrams cover most of the important requirements of EN81-70. There is some additional information listed below which is difficult or impractical to reproduce in a diagram. For all the information you should refer to the complete published specification.

Additional requirements for the landing

- The Car and Landing Doors are automatic, power operated and horizontally sliding.
- Stopping accuracy +/- 10 mm, Levelling accuracy +/- 20mm
- Door dwell time 2 to 20 seconds reduced by door close button
- Door Edge protection <25mm >1800mm sensor preventing physical contact with door.

Although Minimum spec for entrance doors is 800mm, certain local requirements are greater eg. Holland 850mm and Germany 900mm. Also Type 3 lifts require a minimum clear opening of 900mm, see Table 1 and figure 7.

EN81-70 does not cover the landing area dimensions other than to require obstacle free access on all eligible floors, however BS8300 requires a clear manoeuvring space of 1500mm x 1500mm.

Table 1 — Minimum car dimensions for cars with a single entrance or two opposite entrances

Type of lift	Minimum car Dimensions ^a	Accessibility level
1	450 kg Car width: 1000 mm Car depth: 1250 mm	Accommodates one wheelchair user.
2	630 kg Car width: 1100 mm Car depth: 1400 mm	Accommodates one wheelchair user and an accompanying person.
3	1 275 kg Car width: 2000 mm Car depth: 1400 mm	Accommodates one wheelchair user and several other users. It also allows a wheelchair to be rotated in the car.

^a Any decorative finish should not reduce these dimensions by more than 15mm.

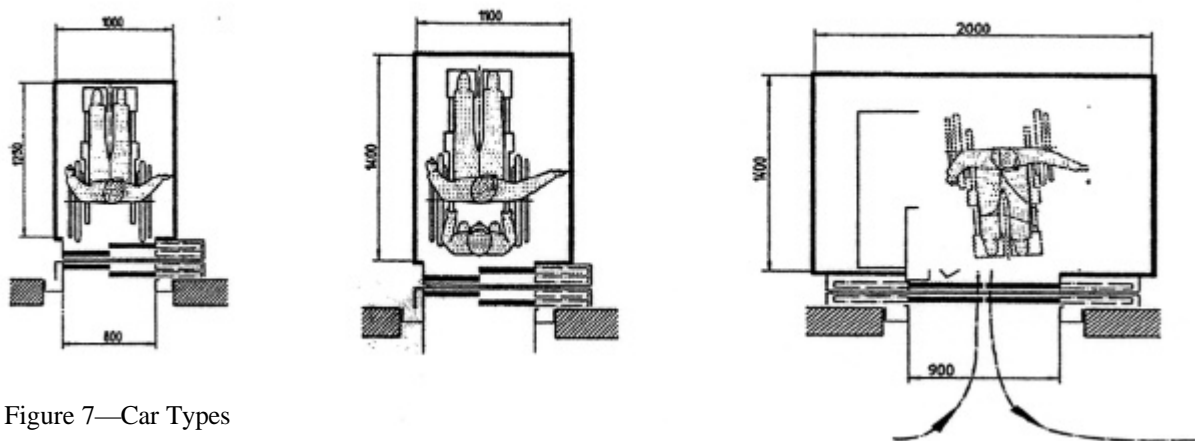

Figure 7—Car Types

- Provision is made for an optional keypad system. For details of this, reference should be made to Annex F of EN81-70.
- Temporary activation control may be provided. If available the button should be marked with the international disabled symbol.
- There are specific provisions for destination control systems. Details of these can be found in section 5.4.3.4 and 5.4.2.5 of EN81-70
- In the case of a single lift where the next direction is audible and visible in the car from the landing, it need not be reproduced on the landing.



On the COP

- Single vertical row of call buttons should go from bottom to top
- Multiple vertical rows from left to right and then bottom to top.

Control Devices

There are additional guidelines about features for the visually impaired in Annex E and about Extra Large control devices in Annex G of EN81-70. Table 2 details the requirements for all control devices both in car and on the landing.

Table 2 —Control devices - Requirements

#	Subject	Landing controls	Car controls
a)	Minimum area of active part of buttons	490 mm ²	
b)	Minimum dimension of active part of buttons	Inscribed circle with a diameter of 20 mm	
c)	Identification of active part of buttons	identifiable visually and by touch from face plate or surrounds	
d)	Identification of face plate	colour to contrast to its surrounds (see D.2)	
e)	Operating force	2,5 N to 5,0 N	
f)	Operating feedback	required to inform user that the button, once pushed, has operated	
g)	Registration feedback	Visible and audible, adjustable between 35 dB(A) and 65 dB(A) ^b . The audible signal shall be given on every individual operation of button even if the call is already registered.	
h)	Button for exit floor	Not applicable	Protrudes (5 ± 1) mm beyond the other buttons (preferably green)
i)	Position of symbol	on active part (or 10 mm to 15 mm left of it)	
j)	Size of symbol (relief)	15 mm to 40 mm	
k)	Height of relief	Minimum 0.8 mm	
l)	Distance between active parts of buttons.	Minimum 10 mm	
m)	Distance between group of call buttons and other group of buttons. ^a	Not applicable	Minimum twice the distance between active parts of call buttons
n)	Minimum height between the floor level and the centreline of any button	900 mm	
o)	Maximum height between the floor level and the centreline of the highest button	1100 mm	1200 mm (preferably 1100mm)
p)	Arrangement of buttons	vertical	See 5.4.2.2
q)	Minimum lateral distance between the centreline of any button to any corner of adjacent walls.	500 mm	400 mm
^a e.g. between alarm-/ door buttons and call buttons.			
^b Adjustable between limits for adaptation to environmental conditions.			

Sections 6 and 7 and Annexes A,B,C & D cover more general information such as accessibility, safety and disabilities considered and provide useful additional material.