

> VM3541-XXXXX

DIGITIZED FLOOR ANNUNCIATOR



MICRO COMM

DIGITIZED FLOOR ANNUNCIATOR

The basic system includes up to eighty different messages, with a total message time of 8 minutes. The unit can be used on the Micro Comm 3 wire network with no additional wires. An option for up/down and door strobe can be signaled at the device.

FEATURES:

- > Custom vocabulary
- > Up to 8 minutes of speech
- > Human Voice
- > Male or female voices
- > Add on to existing P.I.'s
- > Micro Comm inputs
- > Conforms to AGAAG 4,10,13
- > Includes sealed mid-range speaker
- > Receives ASCII

C.E. Electronics Ltd.

Marlow, Bucks, UK | Ph: +44 (0) 1628 487633 | www.cееlectronics.com | Bryan, OH, USA | Ph: (419) 636-6705

C.E. Electronics, Inc.





VM3541-XXXXX

Ver. 2 Rel. 05/20/2011

MICRO COMM[®]

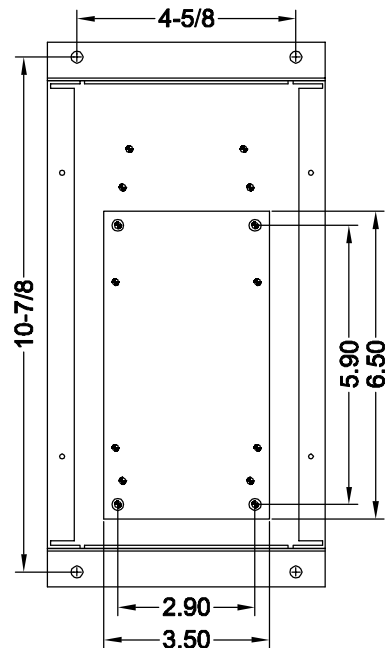
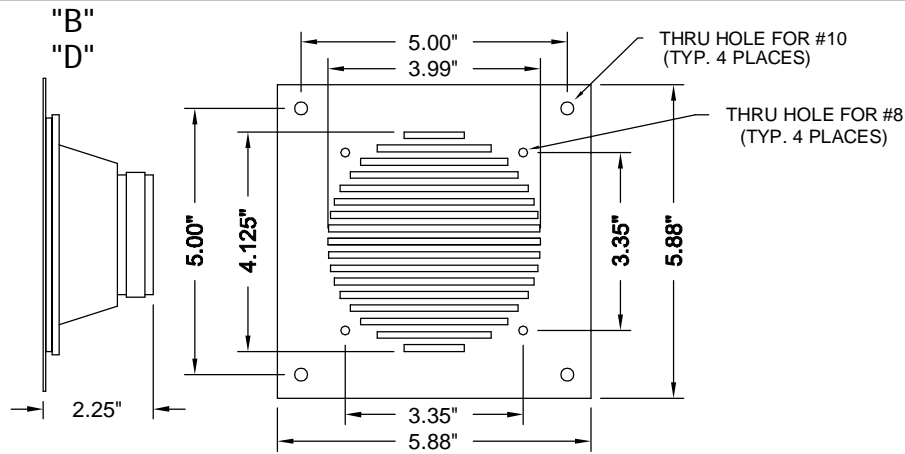
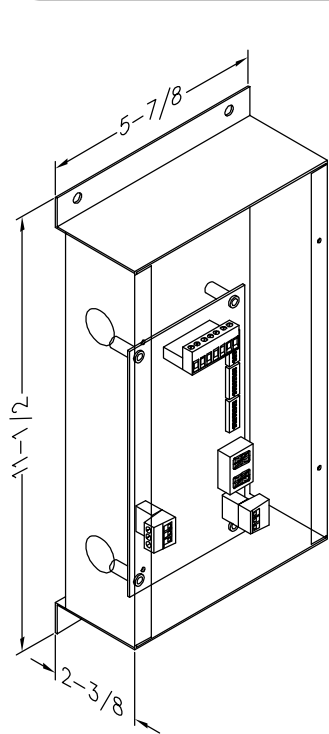

DIGITIZED FLOOR ANNUNCIATOR

The basic system includes up to eighty different messages, with a total message time of 8 minutes. The unit can be used on the Micro Comm 3 wire network with no additional wires. An option for up/down and door strobe can be signaled at the device.

Features:

- Custom vocabulary
- Up to 8 min. of speech
- Human voice
- Male or female voices
- Add on to existing P.I.'s
- Micro Comm inputs
- Conforms to AGAAG 4.10.13
- Includes sealed mid-range speaker
- Receives ASCII

Notes:

1. This is not a stand alone unit. Must be used in conjunction with a Micro Comm interface.

2. The digitized Voice Annunciator (VM3541-XXXXX) must be mounted within 20' of the speaker or damage will result! C.E. #40040001 matching transformers may be purchased for greater distances - consult the factory.

3. If a special voltage is required, please consult factory.

TO ORDER: SPECIFY VM3541 - X X X X X

ARRIVAL ARROW VOLTAGE:

- "A" = POSITIVE 6-20VAC/DC, 24VAC
- "B" = POSITIVE 24-48VDC, 24-48VAC
- "C" = POSITIVE 120VAC
- "D" = POSITIVE 125VDC
- "E" = NEGATIVE 6-20VDC
- "F" = NEGATIVE 24-48VDC
- "G" = NEGATIVE 125VDC
- "M" = MICRO COMM ARRIVAL

DOOR STROBE VOLTAGE/S-BUTTON VOLTAGE:

- "A" = POSITIVE 6-20VAC/DC, 24VAC
- "B" = POSITIVE 24-48VDC, 24-48VAC
- "C" = POSITIVE 120VAC
- "D" = POSITIVE 125VDC
- "E" = NEGATIVE 6-20VDC
- "F" = NEGATIVE 24-48VDC
- "G" = NEGATIVE 125VDC
- "M" = MICRO COMM STROBE

BUILD:
 <BLANK> = with BOX
 "C" = CUSTOM

70V LINE TRANSFORMER
 "R" = REMOTE SPEAKER MOUNT
 "L" = LOCAL SPEAKER MOUNT (NONE)

SPEAKER FORMAT:
 "B" = 2.25" SPEAKER OPTION
 "C" = SPECIAL SPEAKER OPTION
 "D" = WATER RESISTANT SPEAKER OPTION
 "X" = NO SPEAKER

VM3541 VOICE ANNUNCIATOR

JOB# _____

DS1	DS2	DS3	DISPLAY MODE
0	0	0	NORMAL (SHOW FLOORS)
0	0	1	NORMAL (SHOW MESSAGES)
0	1	0	STATUS CODE DISPLAY
0	1	1	CHECKSUM DISPLAY
1	0	X	PLAY TEST
1	1	X	SWITCH TEST

NOTE: SPEAKER WIRE LENGTH MUST BE LESS THAN 20 FEET TO PREVENT AMPLIFIER DAMAGE. FOR LENGTHS GREATER THAN 20 FEET, MATCHING TRANSFORMERS MUST BE USED. CONSULT THE REMOTE SPEAKER CONNECTION DIAGRAM FOR WIRING.

S1 SWITCH DETAIL

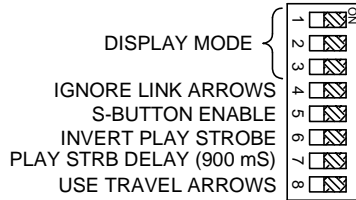

DEFAULT SETTINGS

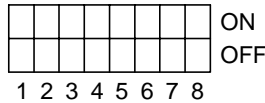

S2 SWITCH DETAIL

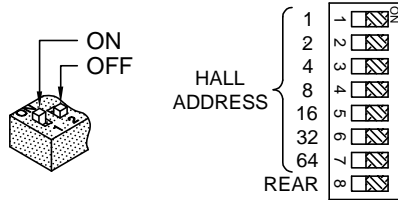

DEFAULT SETTINGS

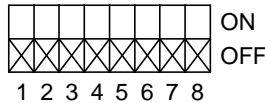

S3 SWITCH DETAIL

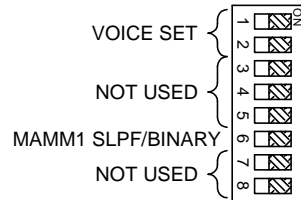

DEFAULT SETTINGS

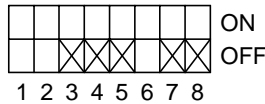

S1 DIP SWITCH SETTINGS

DS1, DS2, DS3 - MODE SELECT - USE TABLE ABOVE TO DETERMINE MODE.

DS4 - ON = IGNORES THE DIRECTION AND PLAY STROBE SIGNALS FROM THE LINK AND USES THE DISCRETE DIRECTION AND STROBE SIGNALS. THE VOICE UNIT STILL USES FLOORS, MESSAGES, AND DESTINATIONS FROM THE LINK.

DS5 - ON = WON'T PLAY FLOORS UNLESS THE S-BUTTON IS ACTIVATED. DESTINATIONS, DIRECTIONS, AND MESSAGES STILL PLAY. IF THE LINK HAS EXPLICIT S-BUTTON CONTROL, THIS SWITCH IS IGNORED.

DS6 - ON = USES AN ACTIVE LOW PLAY STROBE SIGNAL INSTEAD OF AN ACTIVE HIGH SIGNAL.

DS7 - ON = THE UNIT DELAYS PLAYING UNTIL 900 mS AFTER IT RECEIVES THE PLAY STROBE.

DS8 - ON = THE UNIT USES TRAVEL INSTEAD OF ARRIVAL DATA.

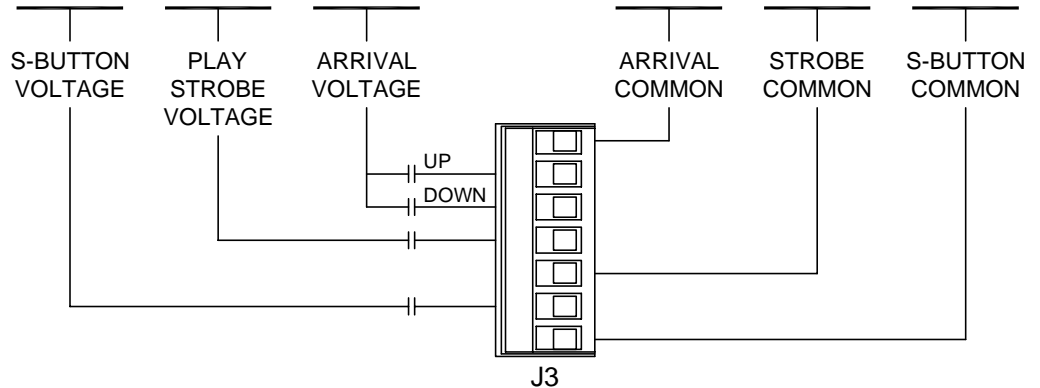
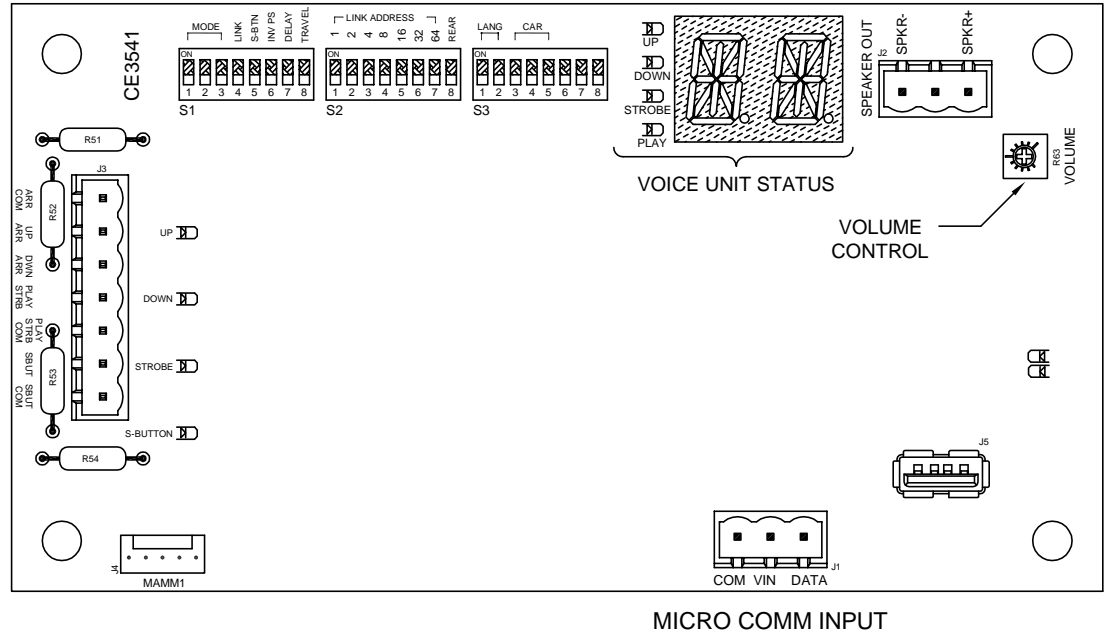

ASCII SCAN SLOT

FLOORS: _____

BOARD VERSION CE3541 _____ ARM CODE VERSION _____

DATE DRAWN: 03/23/11	DRAWN BY: DAC	REQUESTED BY: GE	 C.E. ELECTRONICS, INC. 2107 Industrial Drive Bryan, Ohio 43506 (419) 636-6705
BOARD NUMBER: 3541	LAST DATE REVISED: 04/15/11	APPROVED BY:	
PRODUCT VOICE ANNUNCIATOR WITH MICRO COMM INPUT			DWG. NO. VM3541_01
			REV: B

C.E. ELECTRONICS MICRO COMM VOICE SYSTEM

WARNING! DO NOT APPLY POWER TO THE UNIT WITH THE SPEAKER DISCONNECTED. THIS COULD DAMAGE THE UNIT AND VOID THE WARRANTY!

INITIAL TEST AND SETUP

1. Connect the speaker to the outer terminals of J2 (the center terminal is not used).
2. Connect the Micro Comm signal input to J1.
3. Turn on DIP switch 1 of S1 to start self-test mode.
4. Use a small straight-blade screwdriver to adjust R63 (VOLUME) to a comfortable volume level.
5. Self-test mode plays all of the programmed floor/message announcements (not necessarily in the correct order). Verify the floors/messages meet the job requirements.
6. Turn off DIP switch 1 of S1 to end self-test.

NORMAL OPERATING MODE

1. If discrete signals (non-Micro Comm) are required for car direction, play strobe, or s-button, connect the proper signal wires to connector J3 using the diagram on the other side of this page.
2. The unit should function normally and the *PLAYLED* will light whenever an announcement is active.
3. If the unit fails to operate properly, refer to the TROUBLESHOOTING section below.

TROUBLESHOOTING – If the following steps do not correct the problem, contact C.E. Tech Support at the number below.

1. No sound during self-test
 - a. Verify DIP switch 1 of S1 is *ON*.
 - b. Verify the wires in J1 are properly connected and that the Micro Comm source is *ON*.
 - c. Verify the speaker wires in J2 are properly connected.
 - d. Check the speaker installation. Verify the wires are securely connected.
 - e. Connect another (preferably “known-good”) speaker to the unit.
2. Unit operates in self-test, but sound quality is poor.
 - a. Check the speaker installation. Verify the wires are securely connected.
 - b. Examine the physical speaker installation. Anchor it firmly to prevent vibration during use.
 - c. Connect another (preferably “known-good”) speaker to the unit to see if sound quality improves.
3. Unit operates in self-test with good sound quality, but doesn’t function in normal mode.
 - a. Verify DIP switch 1 of S1 is *OFF*.
 - b. Verify the wires in J1 are properly connected.
 - c. If discrete signals (non-Micro Comm) are required, verify the wires in J3 are properly connected and the signal voltages meet job requirements.
 - d. Verify the required signals are present at the voice unit and at the Micro Comm source. Remember that in most cases more than one signal is required to operate the voice unit.
4. Unit operates in normal mode with good sound quality, but announcements don’t play in the correct order.
 - a. Verify the signal/common wire connections match the diagram on the other side of this page.
 - b. Verify the signals to the Micro Comm source are properly connected.

PLAY STROBE – The play strobe acts as a trigger to activate the floor announcements. Signals typically used for this are *DOORS OPENING* and *CAR SLOWING*, but any signal that occurs at the right time is acceptable.

DIP SWITCH FUNCTIONS – For more information, refer to the diagram on the back of this page.

TIME DELAY FUNCTION – DIP switch 7 of S1 adds a 900-mSec time delay from the time the play strobe occurs to the beginning of the voice announcement. Use the delay in situations where the signal used for the play strobe starts the voice announcement before the correct car position signal is present.

C.E. Electronics, Inc.
2107 Industrial Drive
Bryan, OH 43506

Phone: (419) 636-6705
Fax: (419) 636-2516